



## Applications

Rotating hose joints subject to light bending moment load applications such as small hoses on elevated deck platforms.

## Sizes Available

80mm and 100mm bore mounting flanges to DIN 28460.

## Features

- Aluminium Alloy body.
- Viton Seals.
- Maximum working pressure 10.4 bar (150psi).
- Stainless Steel loose ball type bearings.
- Packed for life - no lubrication required.
- Electrical continuity through unit.



## Specification

The Fluid Transfer Lightweight Aluminium Swivel is designed to give long maintenance free service in light bending moment loading applications.

The flow path is aluminium alloy, thus preventing any possible contamination of the fluid product. The fluid seals are designed to provide minimal resistance to rotation allowing ease of use whilst remaining impervious to kerosene-based fuels.

The reduced weight of the product coupled with the compact size allows it to be fitted in confined spaces where space and weight are a premium. By using the lightweight swivel in applications such as deck hoses both cost and weight are reduced providing value for money efficiency with maximum performance and quality.

**Note :- Unsuitable for high bending moments. FTi Heavy Duty Swivels should be used in these applications.**

# 80mm and 100mm Lightweight Aluminium Swivels

Part No DBA11901/DBA11902

## Technical Data

The swivel is offered in two sizes; 80mm and 100mm with the following features.

- Mounting flanges to DIN28460 series complete with pre-tapped mounting holes.
- Stainless steel ball bearings running in low-friction machined bearing surfaces.
- Viton seals.
- Maximum working pressure 10.4 bar (150psi).
- Maximum test pressure 20.8 bar (300psi).
- Electrical continuity is maintained through the unit.
- No lubrication required.

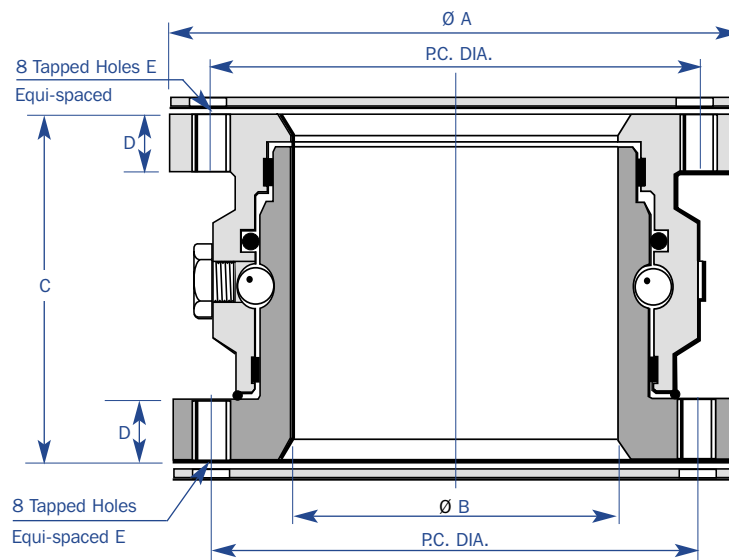

## Dimensions

Swivel Size	A	B	P.C. DIA.	C	D	E	Weight
80mm swivel DBA11902	Ø154mm	Ø80mm	Ø130mm	105mm	18mm	M10	2.7 Kg
100mm swivel DBA11901	Ø174mm	Ø100mm	Ø150mm	115mm	20mm	M12	3.4 Kg

## Service.

Fluid Transfer International offers a full service exchange facility on all our swivels. This allows minimal operational disruption during maintenance schedules with guaranteed product quality.