

105mm SOCKET RANGE

Uses: Used extensively for road tanker bottom loading for a variety of fluids. Automotive fuel, oil, acids and other products.
Connections Available: 2½" and 3" BSP and NPT and Flanged units.

2½" NOMINAL BORE

Material: Aluminium, Bronze, 316 Stainless Steel.
Seals: Standard Viton - others available on request.
Recommended Maximum Flow Rate: 1500 l/min



105mm THREADED TANK UNIT	2½" BSP Aluminium Unit Shown
105mm FLANGED TANK UNIT	3" ASA 150 Aluminium Unit Shown

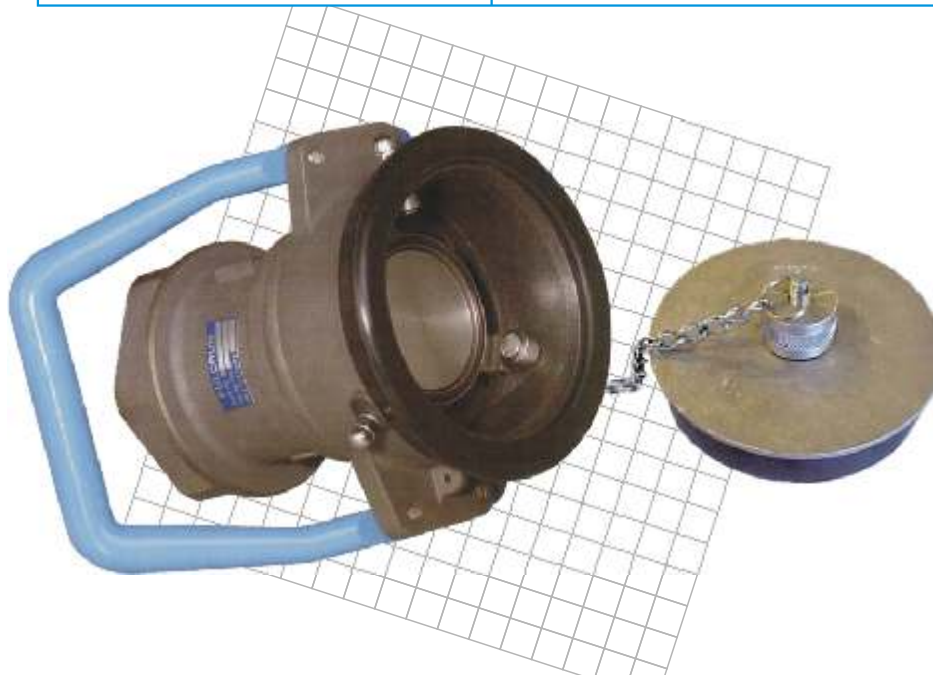

105mm THREADED HOSE UNIT	2½" BSP Aluminium Unit Shown
--------------------------	------------------------------